

# HELI

[www.heliforkliftcanada.com](http://www.heliforkliftcanada.com)

BALANCING ECONOMY WITHOUT COMPROMISING QUALITY.



**FG80P-FG 100P**

**FD80P-FD 100P**

**Gas/LPG, Diesel**

**Pneumatic Tire Forklifts**

8,000-10,000 lbs Capacity



**Legendary Heli Quality**

**Productivity & Reliability**

**Powerful Performance**

**Security & Comfort**

**2 Year Limited  
Powertrain Warranty**



**ISO9001**  
ISO 9001 CERTIFICATION

All Heli forklifts meet or exceed  
ASME B56.1 and CSA B335 Standards

**CE**  
CE CERTIFICATION

# HELI

www.heliforkliftcanada.com



## FG80P-FGI00P and FD80P-FDI00P

Gas/LPG Diesel

Model		FG80P	FG90P	FG100P	FD80P	FD90P	FD100P
Load Capacity	lbs	8,000	9,000	10,000	8,000	9,000	10,000
Load Center	inches	24"					
Lifting Speed (with/without load)	in/s	90	90	84.6	90	90	84.6
Travel Max. Speed (with/without load)	mph	15	11.8	11.8	11.8	11.8	11.8
Max. Drawbar Pull	lbs	4,840					
Gradeability @1mph with/without load	%	19/20	17/18	16/17	19/20	17/18	16/17
Tilt Angle (F/B)	Y degrees	6/12					
Overall Height Fork raised	A inches	177.1					
Max. Fork Height	B inches	130					
Overall height lowered	C inches	99.4					
Free Lift	E inches	5.9					
Overall Length (with fork)	H inches	163.7	164.5	166.2	163.7	166.5	166.2
Overall Length (w/o fork)	I inches	121.6	122.4	124.1	121.6	122.4	124.1
Min. Ground Clearance (bottom of mast)	G inches	6.2					
Overhang (Front/Rear)	K/M inches	22.4/20.4	22.4/21.2	22.4/22.9	22.4/20.4	22.4/21.2	22.4/22.9
Wheel Base	L inches	78.7					
Overall Height (with overhead guard)	P inches	90.1					
Overall Width	Q inches	58.2					
Tread (Front/Rear)	S/T inches	46.4/46.8					
Min. Intersecting Aisle	X inches	107	107.8	110.2	107	107.8	110.2
Min. Turning Radius (Outside)	W inches	131.6	132.4	134.2	131.6	132.4	134.2
Fork size	J/U/F inches	42.1/5.9/2.1			42.1/5.9/2.1		
Engine Model		Nissan TB42			Mitsubishi S6S		
Rated Horsepower	hp/rpm	90/2300			88/2300		
Rated Torque		225/1800			209/1600		
Battery voltage/capacity	V/AH	12/100			2 x 12/70		
Tire (Front)		300-15-18PR			300-15-18PR		
Tire (Rear)		7.00-12-12PR			7.00-12-12PR		
Service Weight	lbs	13,530	14,010	14,630	13,610	14,150	14,760

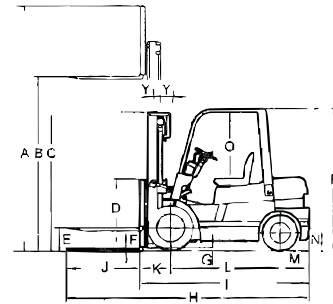
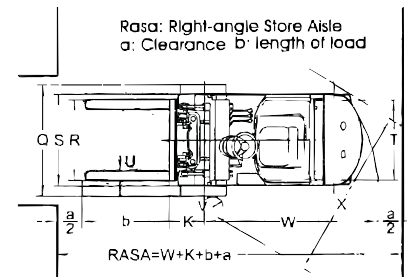

ISO90001  
ISO 9001 CERTIFICATION

CE  
CE CERTIFICATION

### Options include:

- various masts up to 236"
- sideshifts and attachments
- full cabs and rainguards
- air pre-cleaners
- additional lights

All Heli forklifts meet or exceed  
ASME B56.1 and CSA B335 Standards

### Heli Forklift Canada

402 Allanburg Rd.  
Thorold, ON L2V 1A4  
1-877-435-4352 905-227-7554  
www.heliforkliftcanada.com  
sales@heliforkliftcanada.com

Proud to be your authorized Heli Forklift Canada dealer: